

OPERATING INSTRUCTIONS

MINI-MANTRA MINI-MANTRA PLUS MICRO-MANTRA



**ULV- Applicator for weed control
in areas of specialised cultivation such as nurseries, orchards and
vineyards, ornamental plant and vegetable gardens, as well as
agricultural, forestry, communal and non-cultivated lands.**

**The unit has been developed for the *undiluted*
application of ROUNDUP® products (Glyphosate).**

Important:

Before application, carefully read the usage instructions for the unit and the plant protective agent!
Observe safety instructions!

For questions regarding plant protective agents, consult the manufacturer!

Observe the requirements and regional regulations for the use of herbicides and, if necessary,
obtain approval from the responsible authorities (e.g. environmental conservation agency)!

Application is to be performed only by a competent user.

Remarks about usage of the unit:

Settings: This system is not suitable for the application of water.

Use herbicides for testing the spray action and calibration of the flow rate.

Usage: Position the spray hood directly above the ground –
if the spray hood is held too high, the danger of spray driftage exists.

Cleaning: Do not clean the unit with a high-pressure spray or an intense water jet spray.

Storage: Store the unit at an angle of between ca. 45° (= work position) and 0° (= horizontal) to the
floor (see picture).



Keep the applicator and pesticides out of the reach of children.

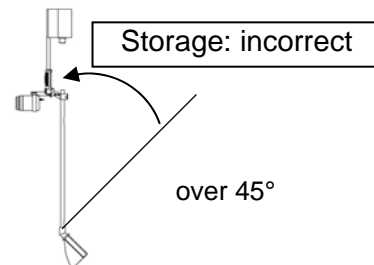
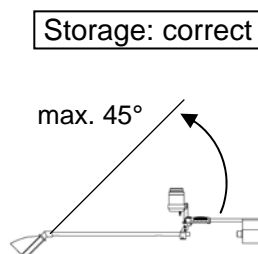
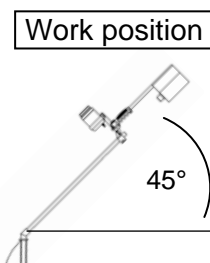

Noise emission from the unit equates to less than 70 dB(A).

Manufacturer:

Mantis ULV-Sprühgeräte GmbH

Germany 21502 Geesthacht, Vierlander Str. 11 a

Telephone +49(0)4152-8459-0, FAX +49(0)4152-8459-11

Web: www.mantis-ulv.eu Email: mantis@mantis-ulv.eu

ASSEMBLY



1. Connect the spray hood to the spray hood holder



2. Screw the flow rate control to the spray hood and spray hood holder

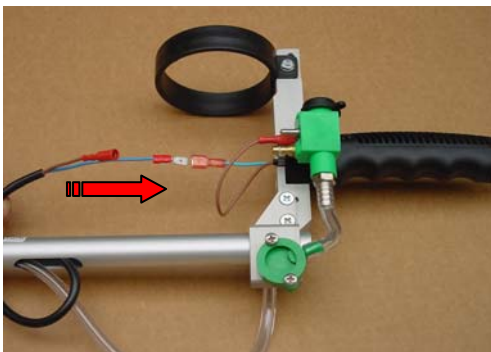

3. Mount the tank bracket to the spray hood holder and secure with knurled-head screw

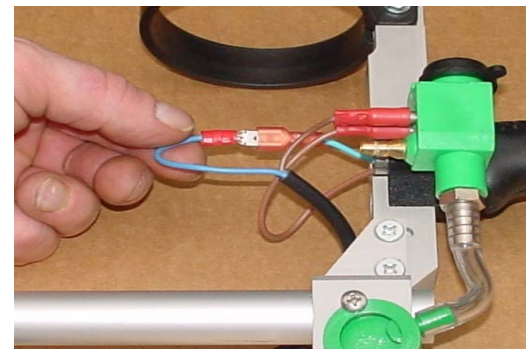

4. Connect electrical wires
(Blue with the blue blade-terminal)
(Brown with the switch/valve unit round pin-plug)

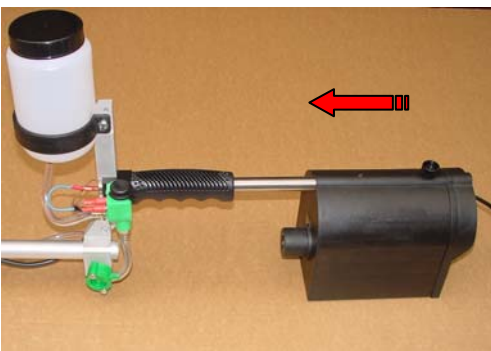

5. Slide the powerpack onto the powerpack holder and secure with a knurled-head screw



6. Plug the phone jack into the socket
Attention: CHARGE BATTERY BEFORE USING!



7. Connect the carrying belt to the tank and powerpack holder



MINI-MANTRA + MINI-MANTRA PLUS + MICRO-MANTRA

For the undiluted application of Roundup® products (Glyphosate)

Intended usage:

Weed control in areas of specialised cultivation such as nurseries, orchards and vineyards, ornamental plant and vegetable gardens, as well as agricultural, forestry, communal and non-cultivated lands.

Before application, carefully read the usage instructions for the applicator and pesticides.

Observe safety instructions.

For questions regarding pesticides, consult the manufacturer!

Observe the requirements and regional regulations for the use of herbicides. Permission is required from the responsible authorities (e.g. environmental conservation agency) for the application of herbicides on surfaces used for non-agricultural, forestry or gardening purposes („non-cultivated lands“). No application is permitted on sealed surfaces (e.g. pavement surfaces) connected to the sewage water system, from which the danger of run-off exists! Application is to be performed only by a competent user.

Noise emission from the unit equates to less than 70 dB (A).

Protective measures

Observe remarks in the usage instructions for the pesticide regarding the safety of the user; wear recommended body protection. Wear protective gloves when filling the chemical.

Do not eat, smoke or drink while working with pesticides. Avoid chemical spillage without fail. After completion of the work, thoroughly clean hands and face. Thoroughly clean and dry the unit immediately following its usage. Never use the mouth to blow out nozzles or other small parts!



Keep pesticides and applicators away from children.

Assembly and preparation for the first application

Assembly of this unit is described on page 2.

Before the first application of the unit, allow the battery to charge for at least 16 hours. First plug the applicator plug into the loading socket, then plug the charging device into the 230 V power outlet. After ca. 16 hours charging time, the battery has reached its full voltage capacity. When the charging process is complete, first unplug the charging device from the 230 V power outlet, then unplug the unit plug from the charger socket.

The spray width should be subsequently checked - ideally with a piece of cardboard laid out on the ground - and the flow rate adjusted (see below for specifics).

General remarks about the function and regarding the first application of the unit

Pesticides: This applicator was originally designed for the undiluted application of Roundup products (Glyphosate). Practical experience has shown, however, that other herbicides can also be deployed in conjunction with this technology. Considering the many products on the market with their differing formulations, it is not possible to provide a complete list with application rate recommendations. The specifications depicted below for adjusting the applicator relate to the usage of Roundup UltraMax (Glyphosate 450 gr/ltr). In general, all products with a comparable viscosity are suitable. If you intend to use a product other than Roundup UltraMax, its application should be initially tested on a trial basis over a small area. In any case, the usage instructions for the chosen herbicide should be observed along with the local requirements.

Applicator function: The rotating atomiser is driven by means of a rechargeable battery. Metering takes place by means of a metering valve. Droplets are formed by the centrifugal force of the rotating atomiser. The droplets are discharged downwards by the rotating atomiser through a step-free, adjustable segment. The residual chemical in the tank, not able to be applied, is approximately 10 ml. This residual fluid can be refilled back into the original herbicide container.

Checking applicator function: Chemicals can flow at differing rates, more quickly or slowly, due to temperature variations. For this reason, the flow rate depicted in the metering table must be checked and corrected as necessary. This technology is not suitable for the application of water. Always use herbicides for testing the spray process and for calibrating the flow rate. Check the rotating atomiser for cleanliness and free turning movement on a daily basis. Check the application volume from time to time throughout the season.

Deployment of the applicator: Position the spray hood directly above the ground - if the spray hood is held too high, the danger of spray driftage exists. During operation, chemical fluid will collect in the atomiser reservoir and will continue to drip for ca. 30 seconds after the stop valve is closed. For this reason, close the valve ca. 1 minute before ending the work task, while the atomiser continues running; then switch the atomiser motor off.

Attention! Before lifting or tilting the spray hood, it is essential that the stop valve is closed and the atomiser motor is switched off.

Setting and verification

Flow rate

- Place an underlay (e.g. cardboard or paper) on the ground.
- Pull out the phone jack from the powerpack (A).
- Fill the chemical tank with herbicide (undiluted).
- Set down the applicator as pictured below.
- Remove the hose from below the flow rate controller. (B)
- Place the measuring cylinder beneath the flow rate controller (see drawing on page 5).
- First set metering valve to maximum.  (D)
- Actuate switch/valve unit (C) and select continuous operation by pressing and turning the button switch in a clockwise direction.
- When the herbicide reaches the metering valve (identifiable in the flow rate controller), the desired setting (see table) is adjusted on the valve. (D)
- Collect the herbicide for 60 sec. in the measuring cylinder.
- If desired quantity is not reached, readjust metering valve and calibrate again.
- Afterwards reattach stereo jack and hose.

Example for the MINI-MANTRA: The setting C is for Roundup UltraMax; 4 ml/min. or 100 drops/min. in the flow rate controller. Deviation from the desired volume can be regulated at the metering valve by setting a greater or lesser flow rate.

Spray width

- Hold the applicator in its working position above the overlay (e.g. cardboard or paper). Actuate the button switch and initially direct the spray hood at the underlay, appraising the spray width at various heights above the section being sprayed. The spray width must be set in such a manner that the droplets are discharged over the entire spray hood width. The optimal spray width is set by the manufacturer under standard operating conditions.
- It is possible to compensate for deviations by loosening the screw (F) and sliding the width adjustment on the atomiser (see drawing).

Working width

- The whole spray hood of MINI-MANTRA and MINI-MANTRA Plus can be turned after loosening the two nuts (spray hood adjustment) and by that working width can be adjusted continuously from 30 to 10 cm (MINI-MANTRA) respectively from 45 to 15 cm (MINI-MANTRA Plus). The nuts must be re-tightened afterwards without fail!
The spray hood of MICRO-MANTRA has a fixed working width of 20 cm.

When the desired volume is obtained, the spray width verified and the working width adjusted, the application process can begin.

- E. Correct rotation direction for disc
- F. Spray width adjustment
- G. Adjust length

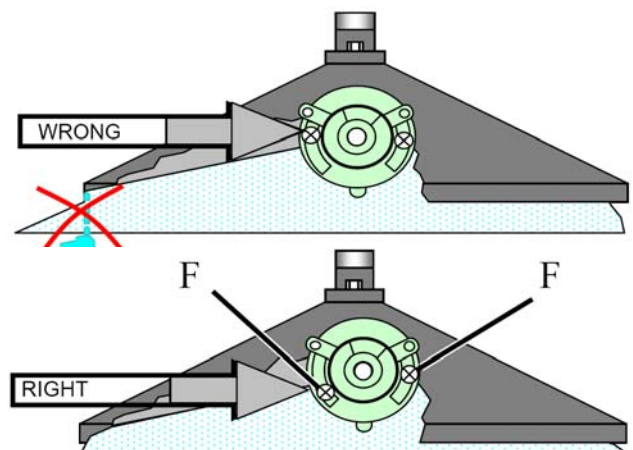
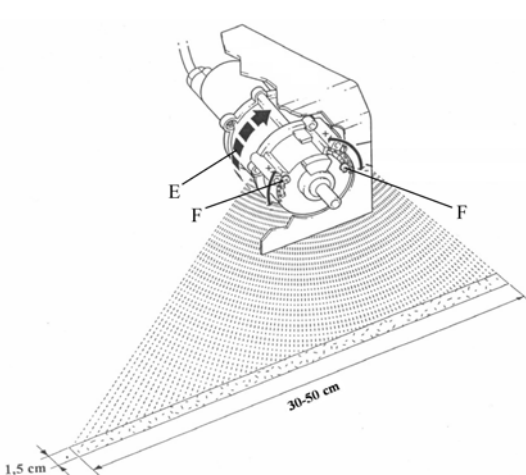
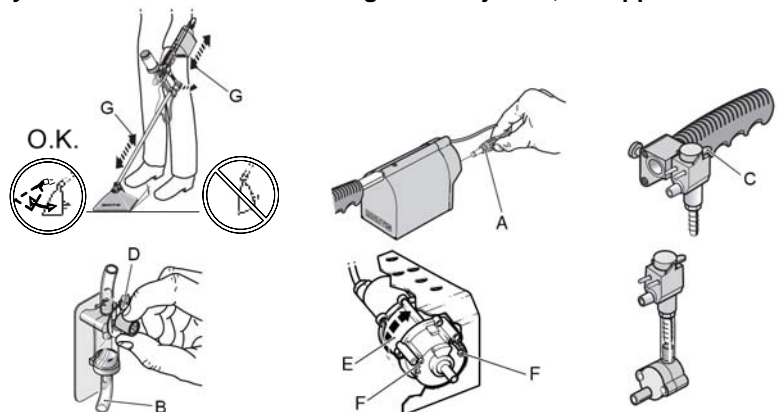

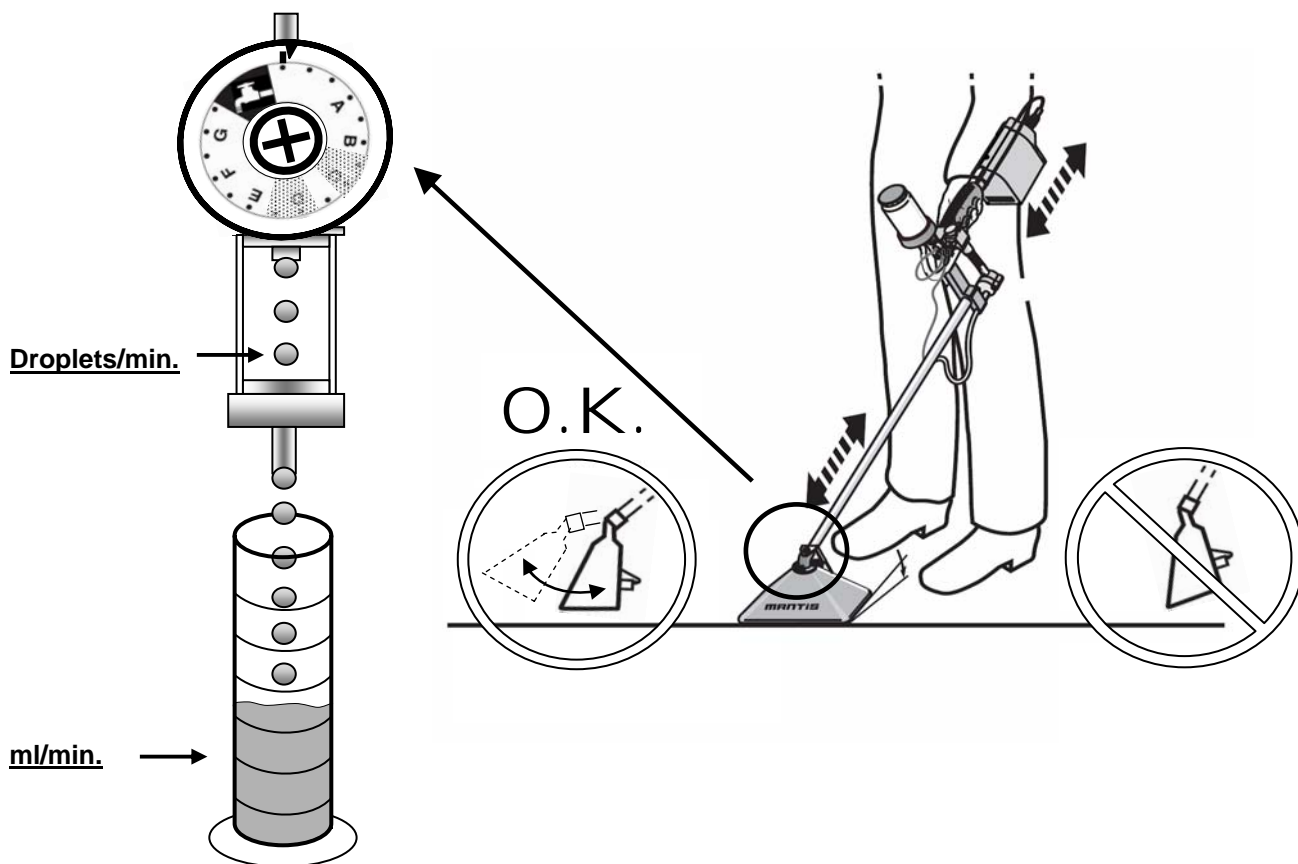

MINI MANTRA Plus at a walking speed of 4 km/h and 20 °C				
applied quantity desired	Pre-position of metering knob		Droplets per minute	ml per minute
	Roudup UltraMax	Basta *		
1l / ha	>A	B	75	3,0
2l / ha	>B	C	150	6,0
3l / ha	E	E	225	9,0

MINI MANTRA at a walking speed of 4 km/h and 20 °C				
applied quantity desired	Pre-position of metering knob		Droplets per minute	ml per minute
	Roudup UltraMax	Basta *		
1l / ha	A	<B	50	2,0
2l / ha	B	>B	100	4,0
3l / ha	>B	C	150	6,0

MICRO MANTRA at a walking speed of 4 km/h and 20 °C				
applied quantity desired	Pre-position of metering knob		Droplets per minute	ml per minute
	Roudup UltraMax	Basta *		
1l / ha	A	>A	33	1,3
2l / ha	>A	B	67	2,7
3l / ha	B	>B	100	4,0

* Basta (Glufosinate-ammonium 200g/l)

Cleaning

Do not clean the applicator with a high-pressure spray or with an intense water jet spray.

Cleaning during the season: During short breaks in the work day (a few hours), the herbicide can remain in the system as long as the metering valve is closed. After completion of work task: before cleaning, return the chemical into its original container. Set the metering valve to maximum (water cock symbol). Fill the chemical tank half way with water, actuate the button switch and allow the atomiser to run for 3 minutes over a collector tank or spread the cleaning fluid over the previously worked surface. Remove the remaining water from the tank.



Cleaning after the season: Rinse the unit with warm water as described above. Additionally: open filter and clean screen if necessary. The spray hood and the atomiser housing can be cleaned with a moist cloth, except the atomiser disc in order to avoid damage. For heavy contamination, the atomiser housing should be unscrewed to remove contaminants and plant parts. Connect the unit to the battery charger (see below).

Charging the applicator and care of the accumulator

The applicator is fitted with an automatic charging device. Trickle charging is possible.

In order to charge a completely empty battery back up to full capacity, ca. 16 hours charging time is required. When a battery is empty, it should be immediately recharged. Never leave a battery discharged for long periods.

Battery charging	Minimum charging time	Time interval
Fully discharged	16 hrs.	immediately
Short-term usage	6 hrs.	immediately
Storage without usage	(2 hrs. 1 x per month)	or permanent charge

The applicator can be used for ca. 16 hours with a fully charged battery.

Fault remedy

Fault	Cause	Remedy
Atomiser disc not turning	Atomiser contaminated Battery empty Fuse blown No electrical contact Battery defective Atomiser motor defective	Thoroughly clean atomiser, remove plant parts if needed Charge battery Replace fuse on powerpack (Replacement fuses are located in the powerpack housing) Check cable or connector contact Install new battery Install new motor Connect the brown cable to Plus (+).
Atomiser spray one-sided	Rotation disc turning in the wrong direction	Connect cable correctly! Selectively plug the brown cable onto the contact pin on the switch/valve unit Connect the blue cable via the round pin plug. Check to ensure the battery connection to the powerpack is correctly poled, blue cable to Plus (+).
Atomiser spray too wide	Width adjustment improperly set	Loosen the screw F (see page 4) and correct the width setting to the left or to the right, respectively
Atomiser drips	Metering valve incorrectly set Atomiser disc defective / contaminated Atomiser spray discharge contaminated	Check setting, see table Replace / clean disc Clean
Atomiser foams	Residual water in system	Completely empty container, hose, segmental atomiser.
Chemical not flowing evenly	Filter contaminated Metering valve clogged	Unscrew filter, clean screen. Set scale to maximum  . Take off hose of upper side of metering valve and blow through with compressed air or use cleaning syringe (accessory art.-no. 100348).
Air in hose line	Hose connection / Filter leaking	Slightly shorten the hose and set onto a hose nipple. Re-tighten the screw on the filter.

Components and spare parts

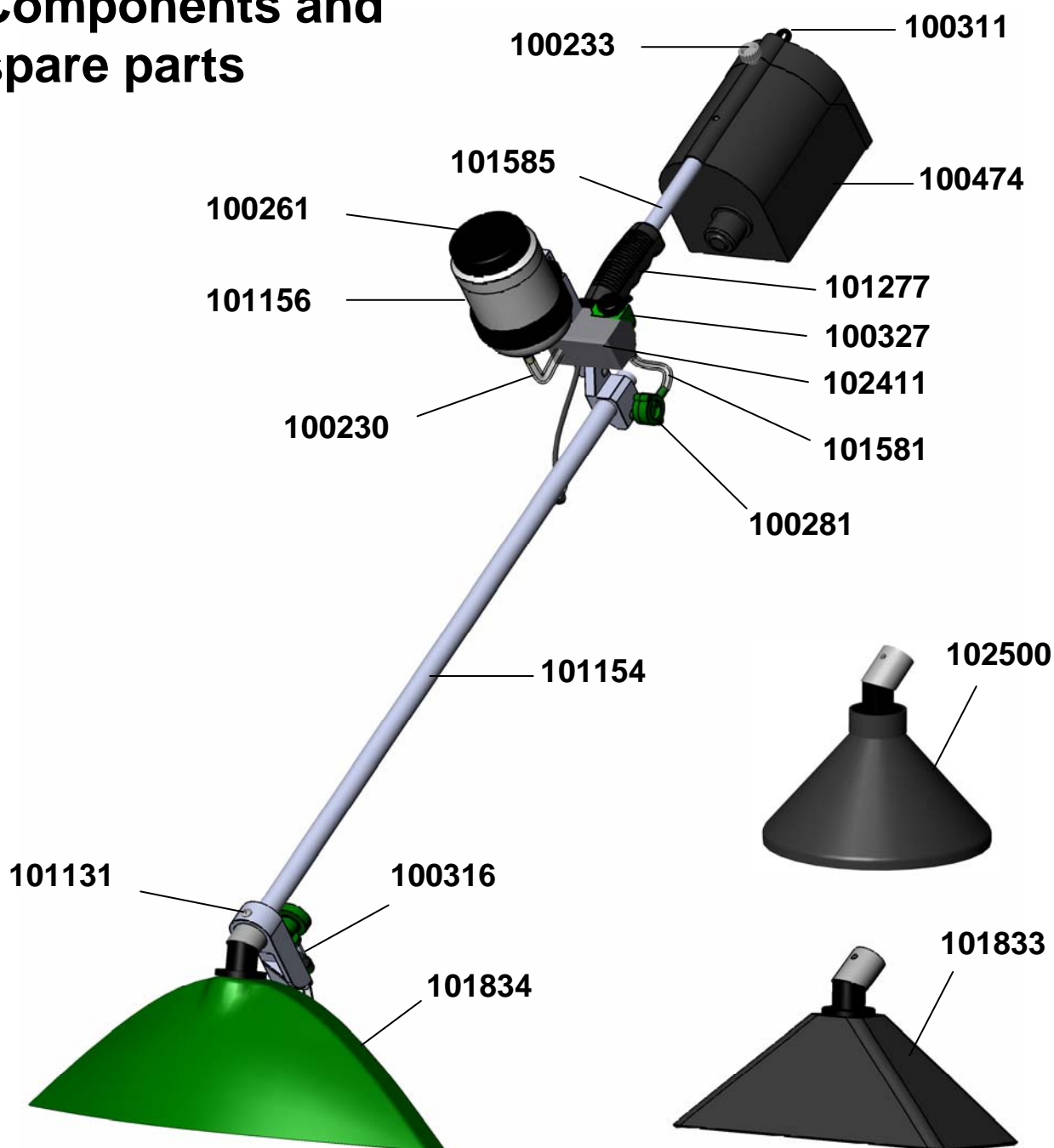

Part No.	Description
100311	Cable with phone jack, 670mm, MINI-MANTRA / Plus
100474	Powerpack with 1 battery 6 V - 7 Ah
100268	Bottle holder kit MINI, holder ALU
100327	Switch/valve unit (complete) gold-plated electrodes, hose nipple incorporated
102411	Cover, for bottle holder MINI-MANTRA
101581	PVC tube 4 x 2 mm, 7 cm
100281	Filter MINI-MANTRA
101154	Spray hood beam, MINI-MANTRA complete
100316	Dosing valve with flow rate controller and bracket for MINI-MANTRA / Plus
101834	Spray hood 45 cm width without atomiser
101131	Pan cross head screw M 5 x 14 mm
100230	Hose PVC, 5 x 2 mm, 13.5 cm for switch/valve unit
101156	Bottle 500 ml with hose connector and scale
100261	Bottle lid
101585	Powerpack bracket, cable, screw, MINI-MANTRA
100233	Knurled-head screw M 5 x 10 mm
102500	Spray hood 20 cm for MICRO-MANTRA compl. without atomiser
101833	Spray hood 30 cm width without atomiser

Components and spare parts

Part No. Description

101972 Atomiser 08, Mini Mantra / Plus

101995	Motor-module for atomiser
100478	Atomiser disc for herbicide atomiser
101996	Segment-module for atomiser incl. width adjustment

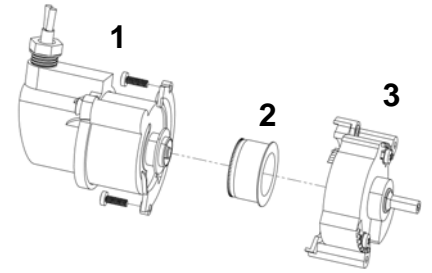

100316 Dosing valve with flow rate controller and bracket for MINI-MANTRA / Plus

101654	Dosing valve with flow rate controller for MINI-MANTRA + MANTRA
100287	Dosing valve bracket

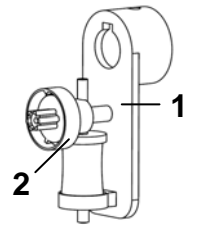

100327 Switch/valve unit (complete) gold-plated electrodes, hose nipple incorporated

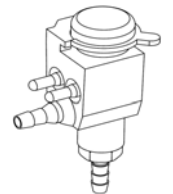

100268 Bottle holder kit MINI, holder ALU

100261	Bottle lid
101156	Bottle 500 ml with hose connector and scale
101277	Bottle bracket, handhold, MINI MANTRA, assembly

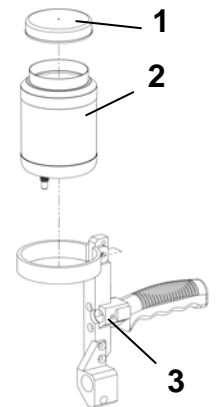

100474 Powerpack with 1 battery 6 V - 7 Ah

100469	Powerpack housing
100450	Storage battery 6V - 7Ah
100460	Cover, powerpack, MINI-MANTRA complete
100730	Fuse T3.15 Amp

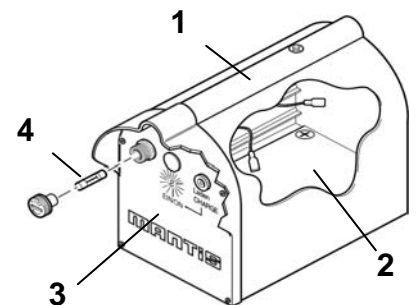

GUARANTEE

The manufacturer guarantees that in accordance with the present state of technology the article of purchase is free from defects as regards raw materials and construction. Guarantee is valid for all machines and apparatus for 24 months. The period of guarantee begins from the date of purchase by the user.

The manufacturer will decide to repair or replace faulty parts or issue a credit note.

Parts damaged due to normal wear and tear will not be replaced under guarantee. Carriage costs are borne by the manufacturer for faulty goods.

Unresolved claims do not entitle purchaser to withhold payments or set them against non-approved claims. Parts not manufactured by manufacturer are guaranteed by the original manufacturer under their terms. Warranty claims must be submitted in writing within 4 weeks of the damage being seen.

Repairs will be carried out with original manufacturer spare parts by an approved dealer.

Acknowledgement of a claim by manufacturer is binding only when a written notice is issued. Unless the manufacturer cannot make a repair, there is no right to cancellation of orders or to mitigation. Compensation for direct or indirect damage will not be given.

Guarantee terminates if the article of purchase is altered by manipulation of third parties or by installing spare parts of extraneous origin and if the ascertained damage is directly caused thereby. Guarantee also terminates if orderer does not observe the operating instructions.

Guarantee does neither apply to natural wear, to damage caused during storage or by corrosion, nor to damage caused by negligent or improper handling. Guarantee does not apply to used machines or apparatus.

The operation instruction published by the manufacturer has been carefully prepared and is based on extensive tests.

Since manufacturer have no influence on installation and handling of apparatus, the company will not assume any responsibility for lack of success or for damages caused by the apparatus itself or by its use.

EG-Declaration of conformity Council Directive 2006/42/EG

Mantis ULV-Sprühgeräte GmbH, Vierlander Straße 11 a, 21502 Geesthacht declares under our sole responsibility that the following products are in conformity with the provisions of the following Council Directive: 2006/42/EG

Typ	MANKAR-P, MANKAR-110-P, MANKAR-110-GP, MANKAR-L, MANKAR-110 SELECT EL
Typ	MANTRA, MINI-MANTRA / PLUS, MICRO-MANTRA, MICRO-VASO
Typ	FLEXOMANT-1W, FLEXOMANT-2W, FLEXOMANT-3W, FLEXOMANT-4W, FLEXOMANT-PLUS, VARIMANT-1, VARIMANT-2, VARIMANT-4 PLUS, VARIMANT-WINNER-TOP, VARIMANT-WINNER-UNO
Typ	MAFEX
Typ	ROFA

André Verder
Managing Director

Geesthacht January 2009

(Place and date of signature)

(Name, title and signature)